

SEMI AUTOMATIC DOORS

Single panel doors



NEW & EXISTING INSTALLATION
MODERNIZATIONS AND REPLACEMENT



RESIDENTIAL
LIFTS



Door configuration





LIFT APPLICATION

Door cycles per year:	Up to 350.000.
Traffic peak of the door:	Up to 240 cycles per hour.
Traffic lift speed:	Up to 2,5 m/s.

APPLICATION RANGE

Opening	Clear opening - CO (mm)	Clear height - CH (mm)
T1	500 - 1000 (Classic)	1500 - 2350
T1	500 - 1000 (Classic Blind)	1500 - 2350
T1	600 - 1000 (C310 "Luxury")	1100 - 2350
T1	600 - 1000 (C520 "Big vision")	800 - 2350
T1	600 - 1000 (C710)	2000
T1	600 - 1000 (M310 "Elegance")	1100 - 2350
T1	600 - 1350 (Classic heavy duty)	2000 - 2950

PANELS

Opening	Sheet metal	Small vision	Big vision	Aluminium glass	-
					-
x	✓	✓	✓	x	-

FRAMES DEFINITION

Frame depth (mm)	Jamb J1 (mm)	Header - HD (mm)	Jamb J2 (mm)	Remarks	Frame type				Option			
					STD	MSS MV	MSS MH	Con-cealed	Lateral covers	Without extra stroke	MRL	Without Lateral Punching
50	125	125	125	-	✓	x	x	x	x	x	x	x

STANDARDS

Opening	EN 81-1/2 Safety rules	EN 81-21 Existing buildings	EN 81-28 Remote alarm	EN 81-41 Impaired mobility	EN 81-71 Vandal resistance lifts		EN 81-72 Firefighters lifts	EN 81-20/50 Safety rules
					Cat. I	Cat. II		
T1	✓	✓	x	x	x	x	x	✓

Available⁽¹⁾. Not available.  Ask the commercial department.

⁽¹⁾Some option combinations may not be possible.

Door configuration







PROTECTION

Opening	IP20 Protection against a solid foreign body of 12,5 mm or more in diameter.	IP40 Protection against a solid foreign body of 1 mm or more in diameter.	IP54 Protection against dust and protected against water splashed from all directions.	IP67 Sealed against dust and protected against temporary water immersion (up to 1 meter for 30 sec)
T1	✓	✓	✓	✓

COMPATIBLE LOCKS

Manufactured by	Description	Lock options	Safety contact options
TI-Electrometal	Mechanic lock	IP20	IP20
Kronenberg	Mechanic lock	IP40 / IP54 / IP67	IP20 / IP67
	Electric lock	IP40 / IP54	IP20 / IP67
Schmersal	Mechanic lock	IP54	IP 54

COMPATIBILITY

Cam detail						
Case	Automatic horizontal sliding car door 40/10 PM, 50/11PM, 40/10 VF, 50/11 VF					Automatic folding car door G3, G5, G5-EM
Coupling	Sliding cams					Folding cams
Type of cam	Frontal retractable	Inverted lateral retractable	Lateral retractable	Fixed	Flexible Fixed	Lateral retractable
Toe guard type	Standard	Standard	Standard	Standard	Standard	Standard
Toe guard height	270	270	270	270	270	270
Thickness	2	2	2	2	2	2
Range	All	All	All	All	All	All

Available⁽¹⁾. Not available.  Ask the commercial department.

⁽¹⁾Some option combinations may not be possible.

Technical features

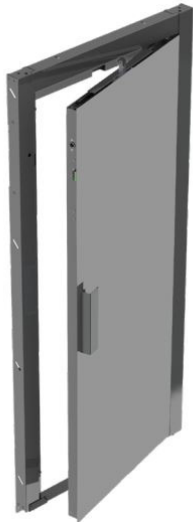

Sheet metal



Small vision



Big vision

GENERAL FEATURES

Total weight	Reference: T1 PL800 mm HL 2000 mm with vision panels - 70 kg
Self closing system	Spring Optional : DITEC (button actuated system)

INSTALLATION

Pre-adjusted and tested to simplify the installation.

Technical drawing

CLASSIC

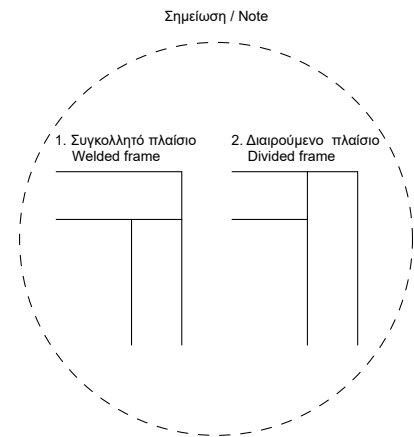
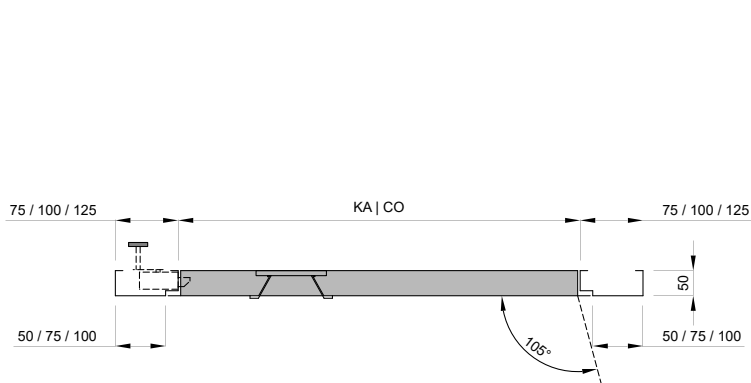
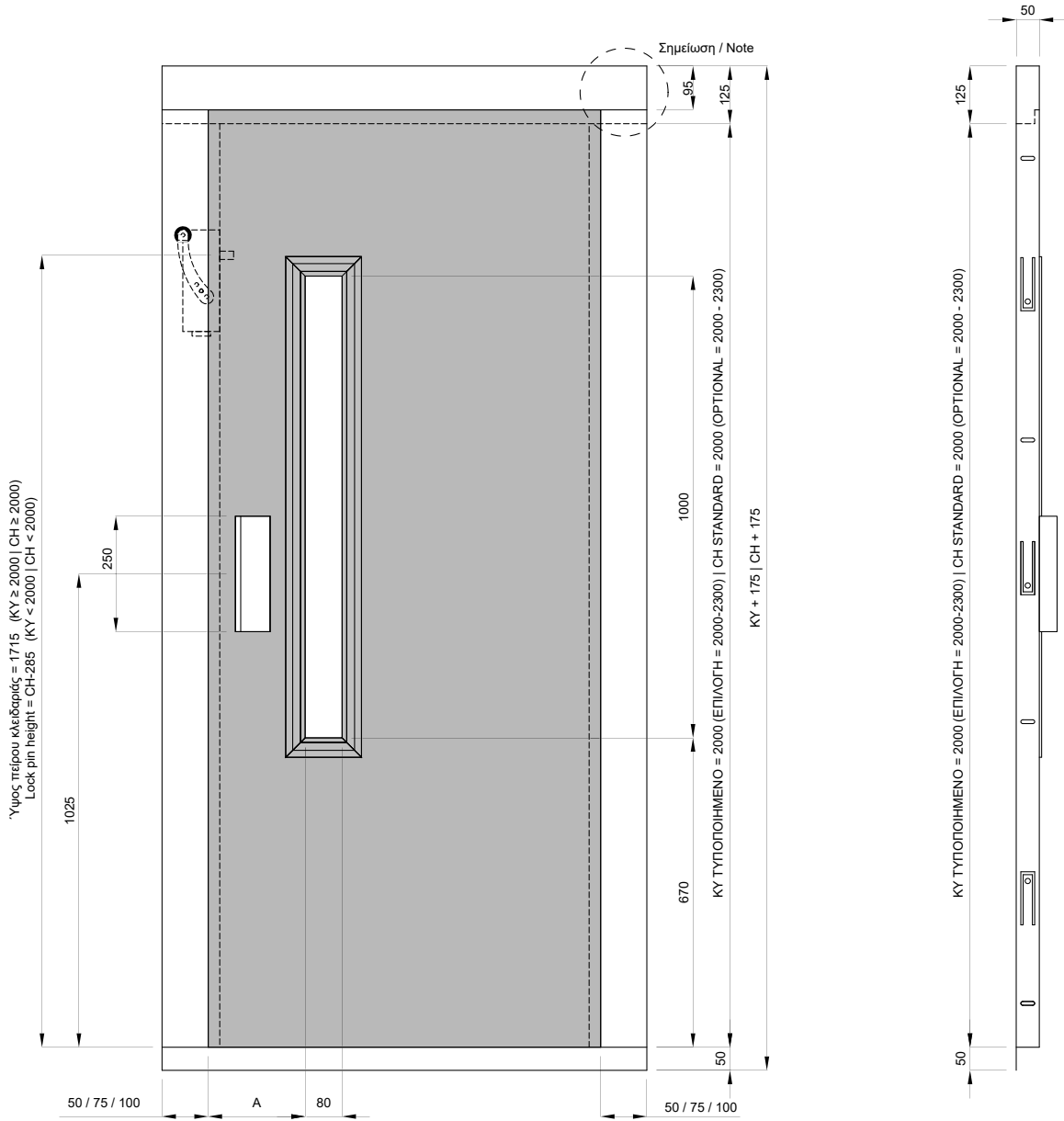

CO	500	550	600	650	700	750	800	850	900	1000
A	157	157	157	157	182	182	207	207	232	257

Technical drawing

CLASSIC blind

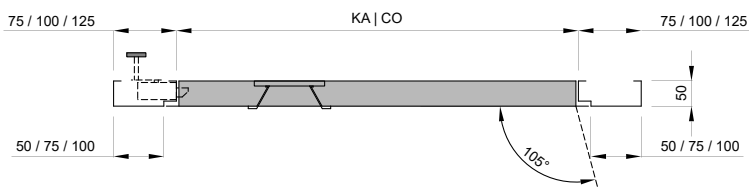
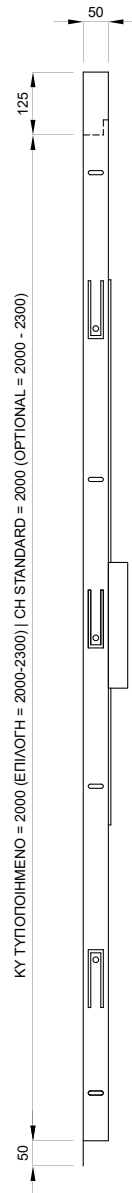
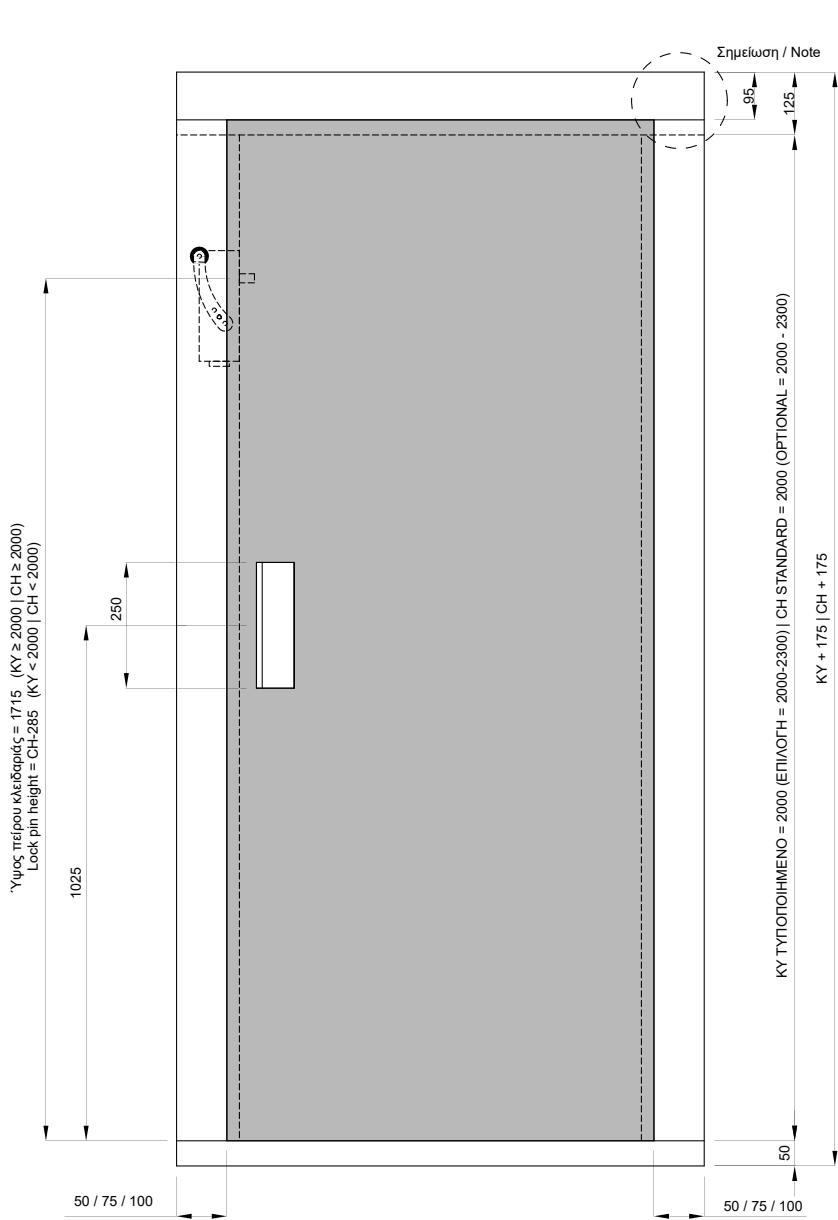

Σημείωση / Note

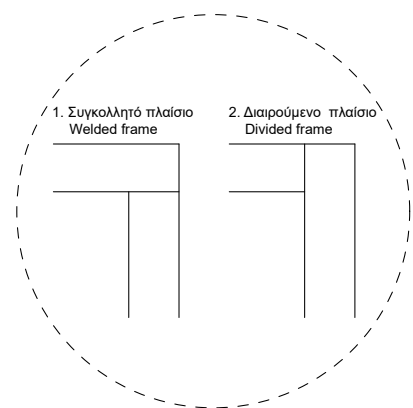

Technical drawing

C310 "Luxury"

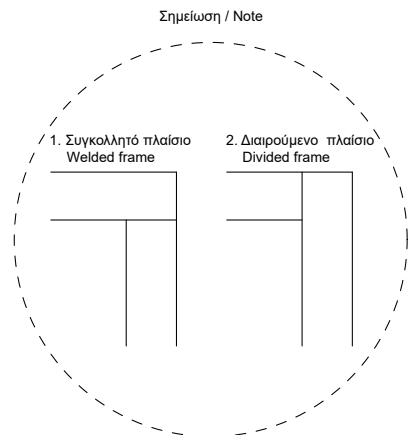
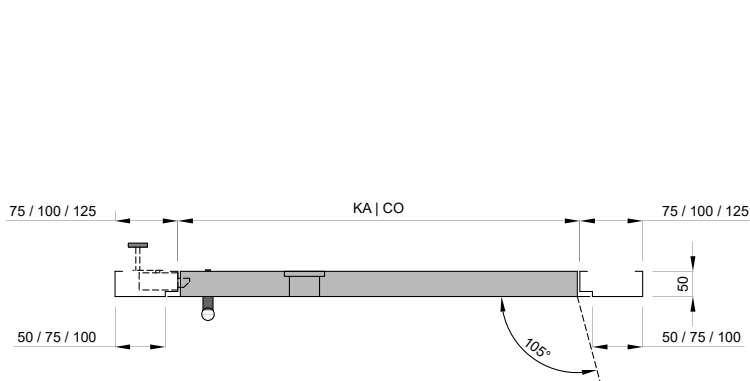
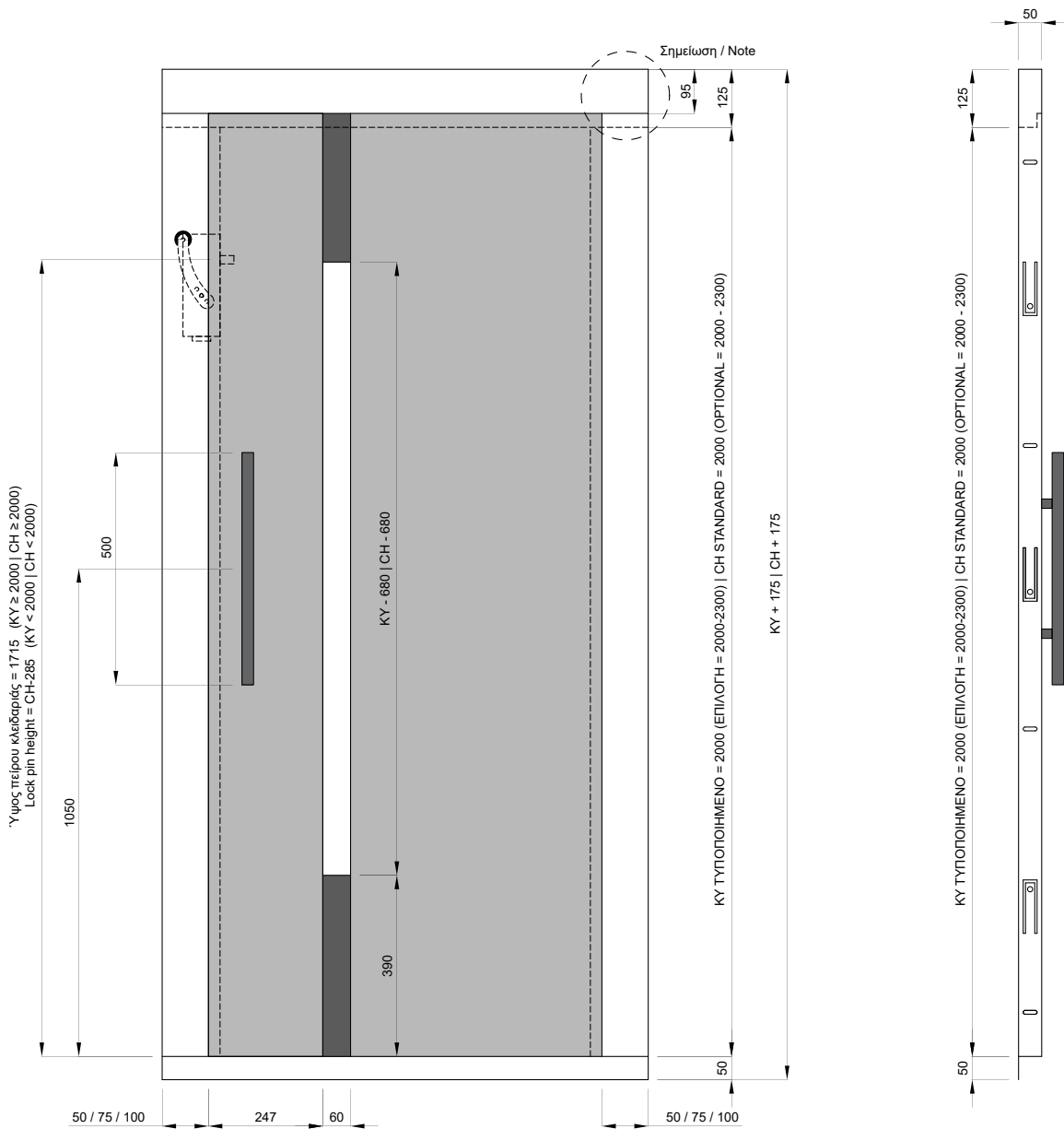

Technical drawing

M310 "Elegance"

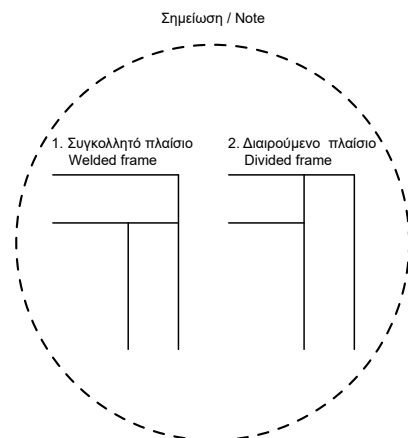
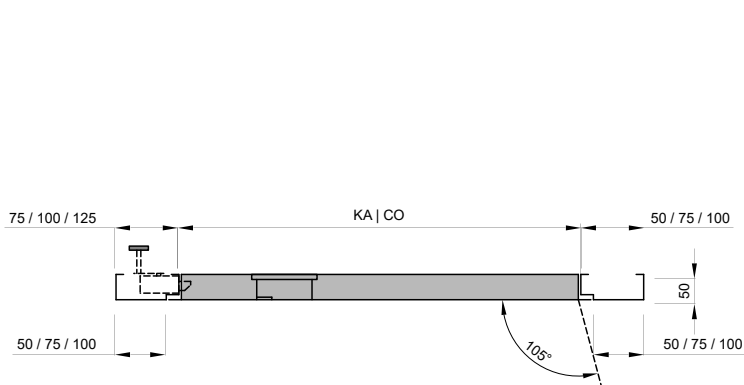
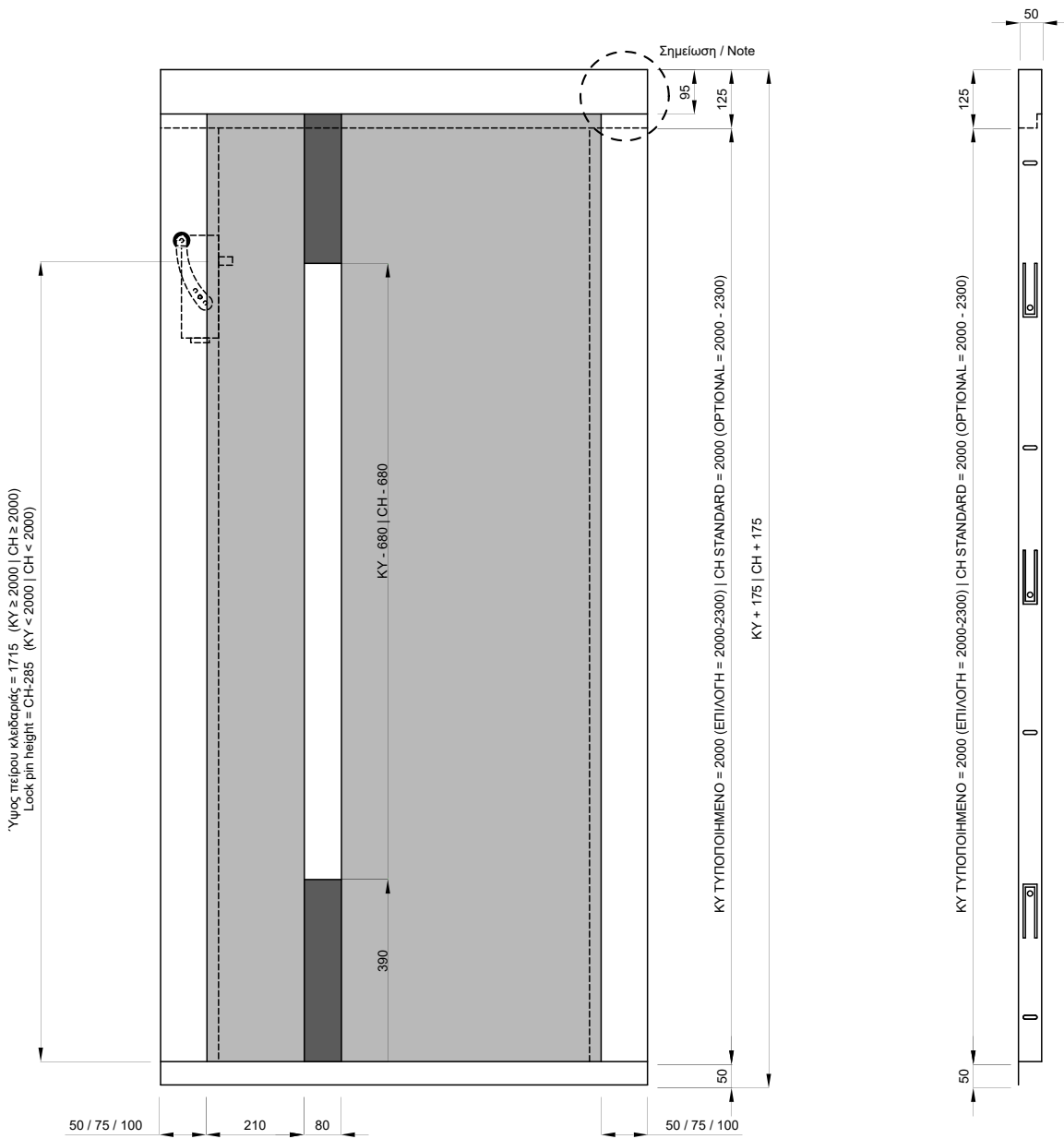

Technical drawing

C520 "BIG VISION"

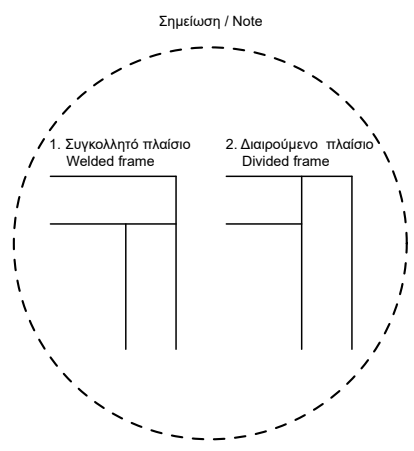
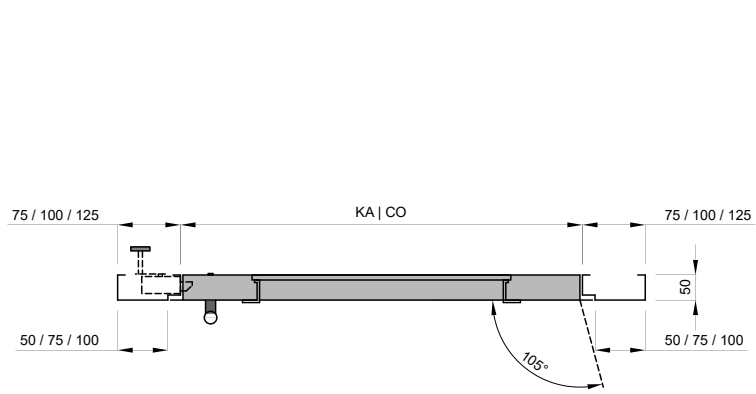
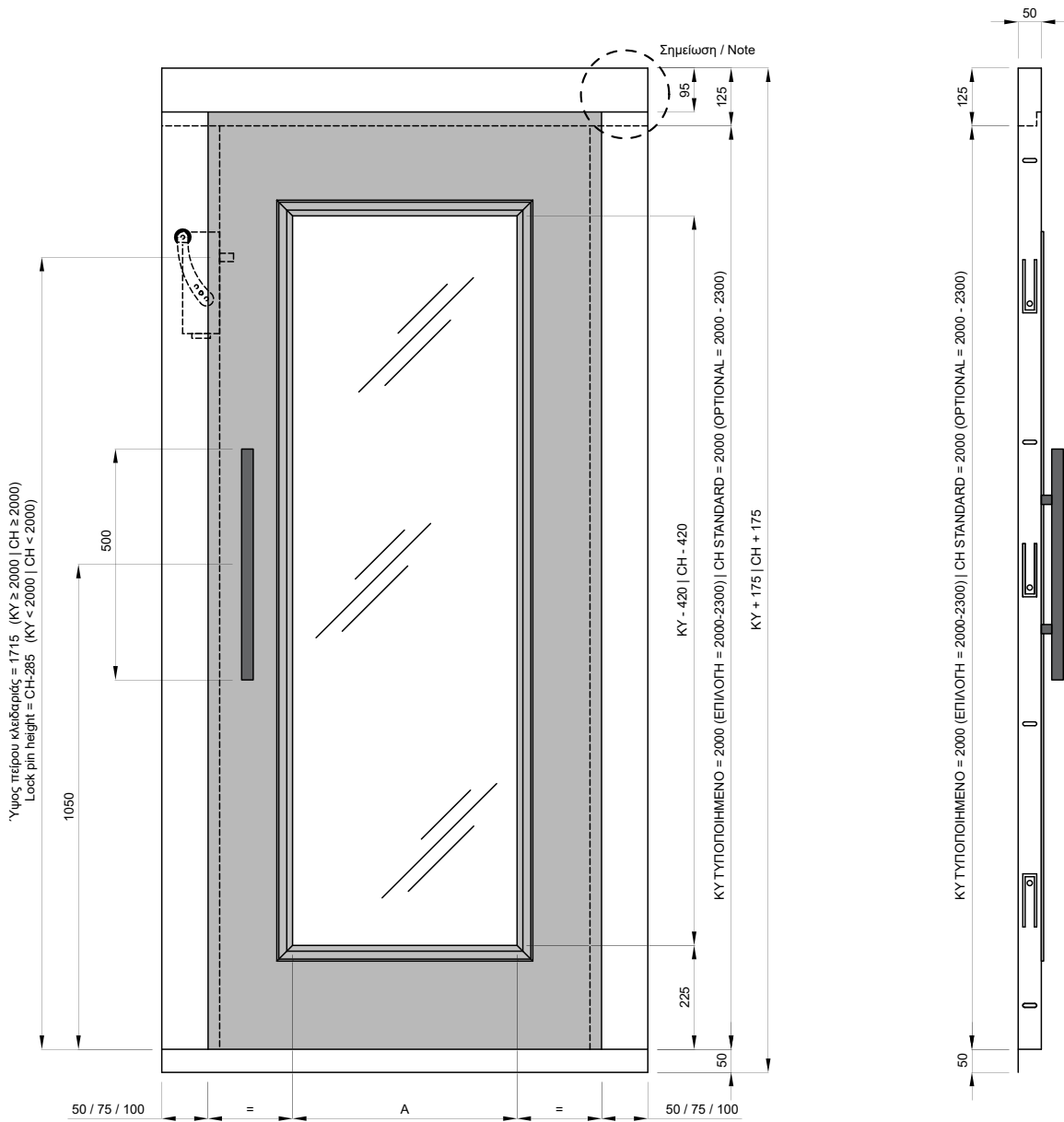

CO	600	650	700	750	800	850	900	950	1000
A	385	385	485	485	585	585	685	685	785

Technical drawing

C710

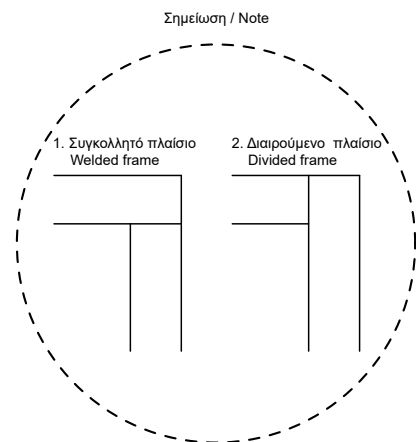
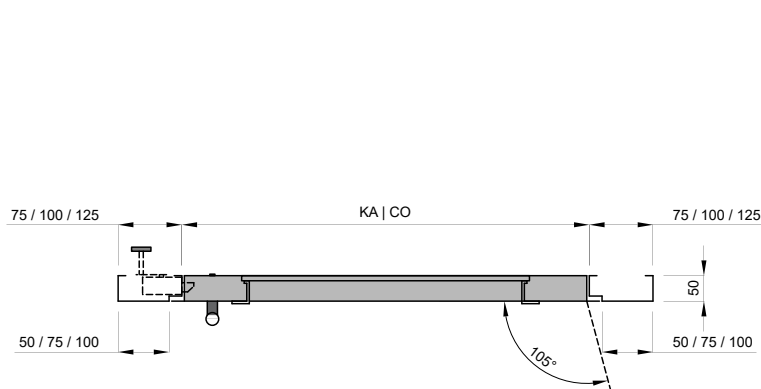
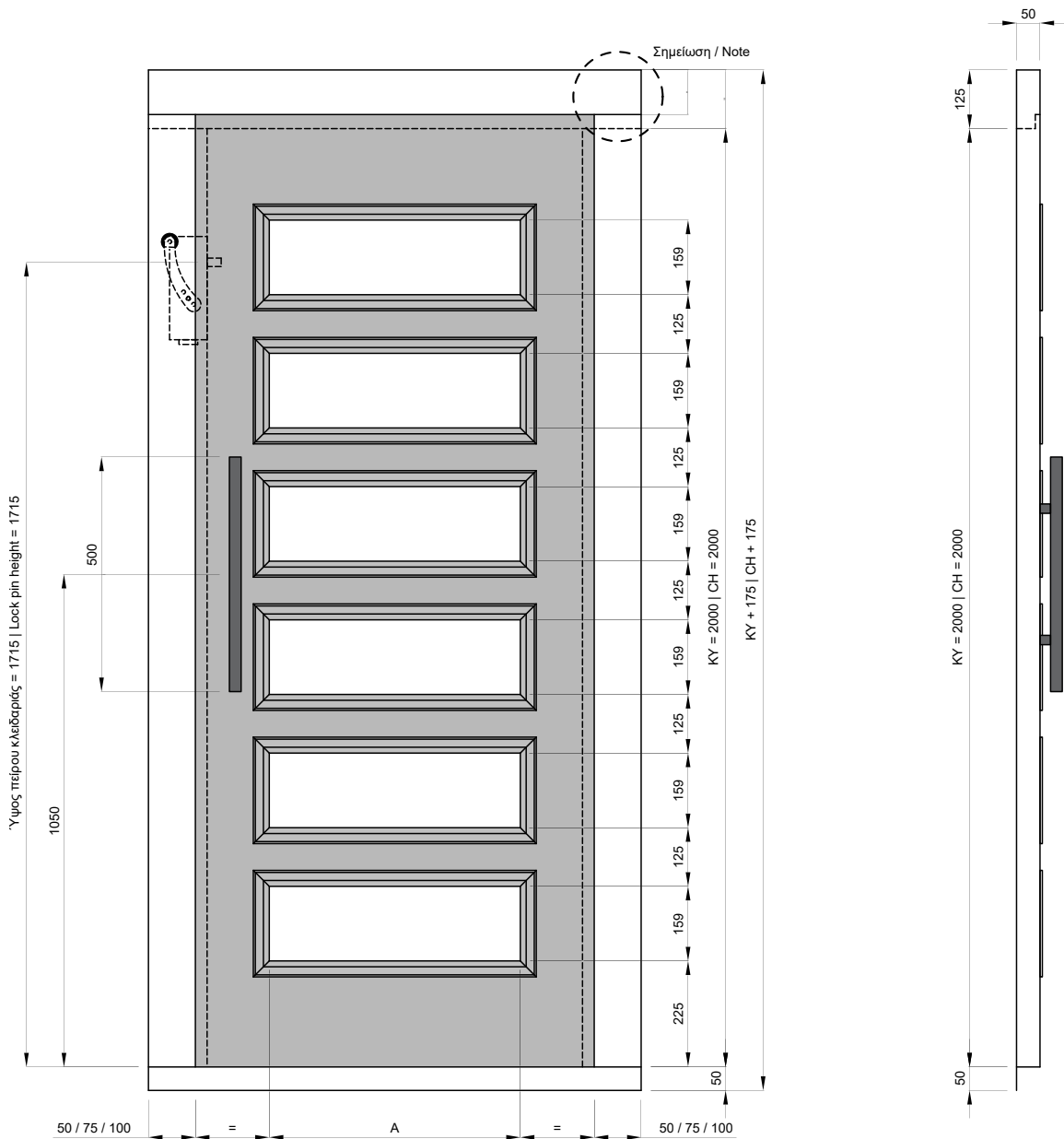

CO	600	650	700	750	800	850	900	950	1000
A	385	385	485	485	585	585	685	685	785

Technical drawing

Classic heavy duty

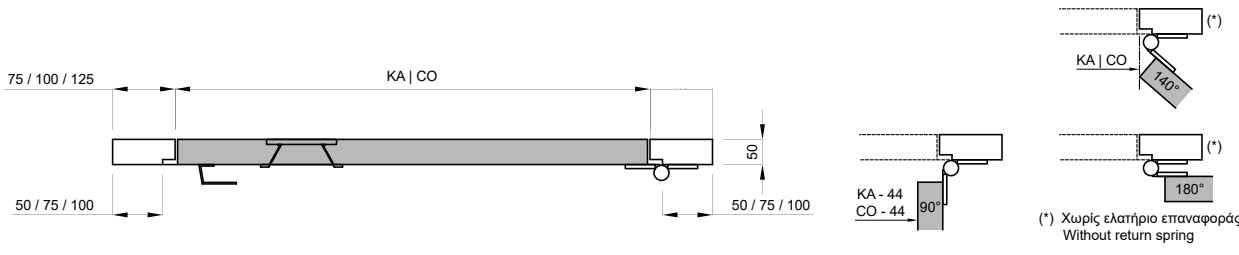
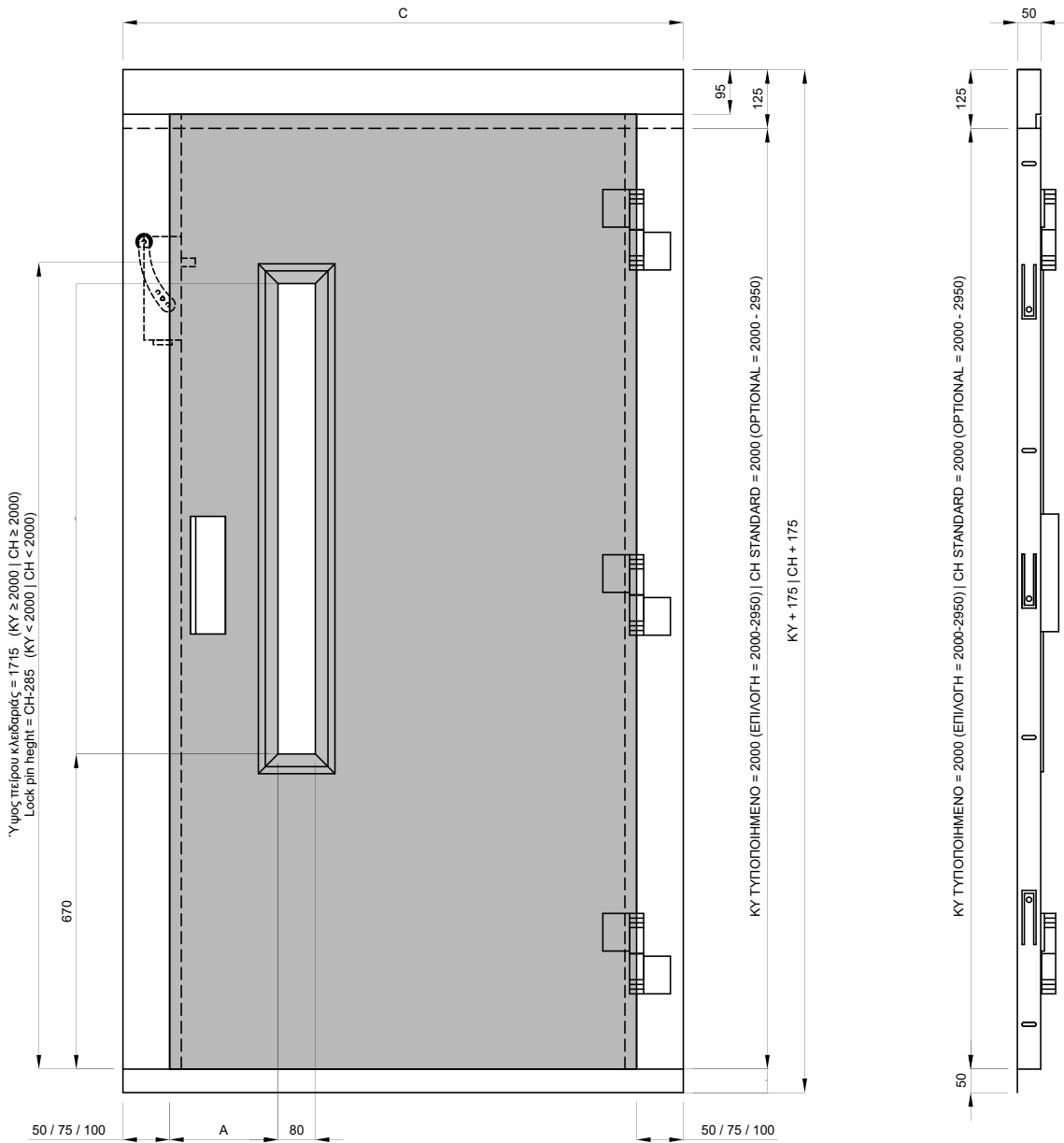

KA x KY > 2m² | CO x CH > 2m²

CO	600-850	900	950	1000	1050	1100	1150	1200	1250	1300	1350
A		232	232	257	257	282	282	282	282	282	282



KLEFER S.A.

KILKIS Business Park 61100
KILKIS (GREECE)
Tel.: +30 23410 75730 - 2
General Commercial Register (GEMI): 014504535000
National Producers Register Nr.: 2581

Sales contacts

General: commercial@klefer.com

www.klefer.com