

MODEL G5 - EM

Automatic folding car door



EXISTING INSTALLATION
MODERNIZATIONS AND REPLACEMENT



RESIDENTIAL
LIFTS



Door configuration





LIFT APPLICATION

Door cycles per year:	Up to 350.000.
Traffic peak of the door:	Up to 180 cycles per hour.
Traffic lift speed:	Up to 2,5 m/s.

APPLICATION RANGE

Opening	Clear opening - CO (mm)	Clear height - CH (mm)
C4	500 - 950 (Sheet metal)	2000 & 2100
C4	600 - 950 (Small vision)	2000 & 2100
C4	750 - 950 (Big vision)	2000 & 2100

PANELS

Opening					-
	Sheet metal	Small vision	Big vision	Aluminium glass	
					-
x	✓	✓	✓	x	-

SILLS

Type of sills	Aluminium	Reinforced aluminium	Stainless steel	Steel	Massive
Profile detail		-	-	-	-
Availability	✓	x	x	x	x
Heated sill option	x	x	x	x	x
Dust holes	✓	x	x	x	x
Sill support	x	x	x	x	x

STANDARDS

Opening	EN 81-1/2 Safety rules	EN 81-21 Existing buildings	EN 81-28 Remote alarm	EN 81-41 Impaired mobility	EN 81-71 Vandal resistance lifts		EN 81-72 Firefighters lifts	EN 81-20/50 Safety rules
					Cat. I	Cat. II		
C4	✓	✓	x	✓	x	x	x	✓

Available⁽¹⁾. Not available.  Ask the commercial department.

⁽¹⁾Some option combinations may not be possible.

Door configuration

PROTECTION

Opening	IP21 Protection against a solid foreign body of 12,5 mm or more in diameter and protected against vertically falling drops of water.	IPX3 Protected against sprays of water up to 60 degrees from the vertical.	IP54 Protection against dust and protected against water splashed from all directions.		IP65 Sealed against dust and protected against jets of water from all directions.	EEx Explosion proof, Group II (surface industries) and Category 2 (explosive atmosphere between 10 and 1.000 hrs/yr).
			Magnetic contacts	Mechanical contacts		
C4	✓	✗	✗	✗	✗	✗

SAFETY DEVICES

Opening	Photocell	Photoelectric barrier	Safety edge	Emergency power supply
C4	✗	✗	✗	✓

PANEL GUIDE

Type of panel guide	Circular	
---------------------	----------	---

COMPATIBILITY

Cam detail	
Case	Semiautomatic hinged landing door.
Coupling	Cams
Type of cam	Lateral retractable

Available⁽¹⁾. Not available. Ask the commercial department.

⁽¹⁾Some option combinations may not be possible.

Technical features

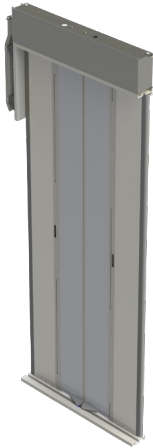

Available.

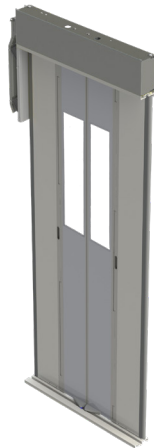

Available.



Available.

DRIVE

Type	Brushed DC motor with worm gearing.	
Power	8 W.	
Transmission	PL 500 - 950 mm.	Motor drives a cam.

ELECTRONIC MODULE

Type	G5 Electromagnetic lock.
Working signals available	From 85 V to 230 V AC/DC.
Opening speed	Up to 0,6 m/s.
Closing speed	Up to 0,6 m/s.
Re-opening	Integrated.

OTHER FEATURES

Total weight	Reference: C4 PL 850 mm HL 2.000 mm with sheet metal panels - 78 kg.
Locking device	Car Door Lock.

INSTALLATION

Pre-adjusted and tested to simplify the installation.

Technical drawing

SHEET METAL

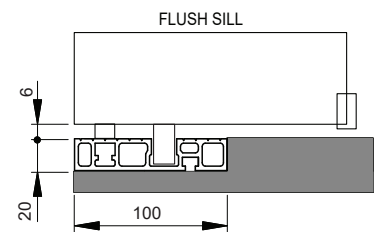
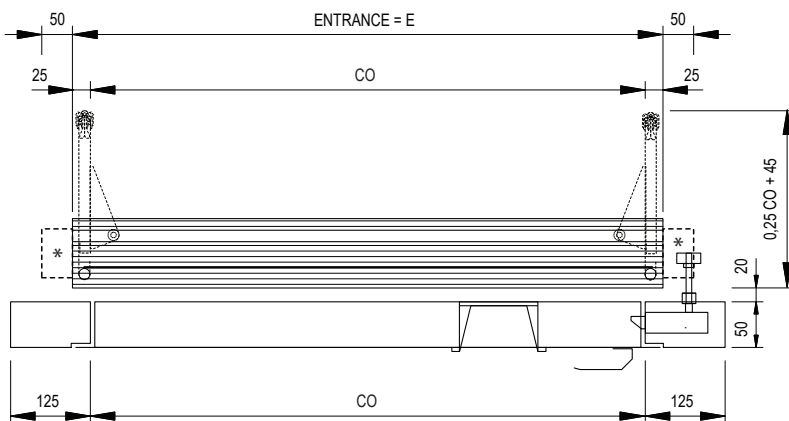
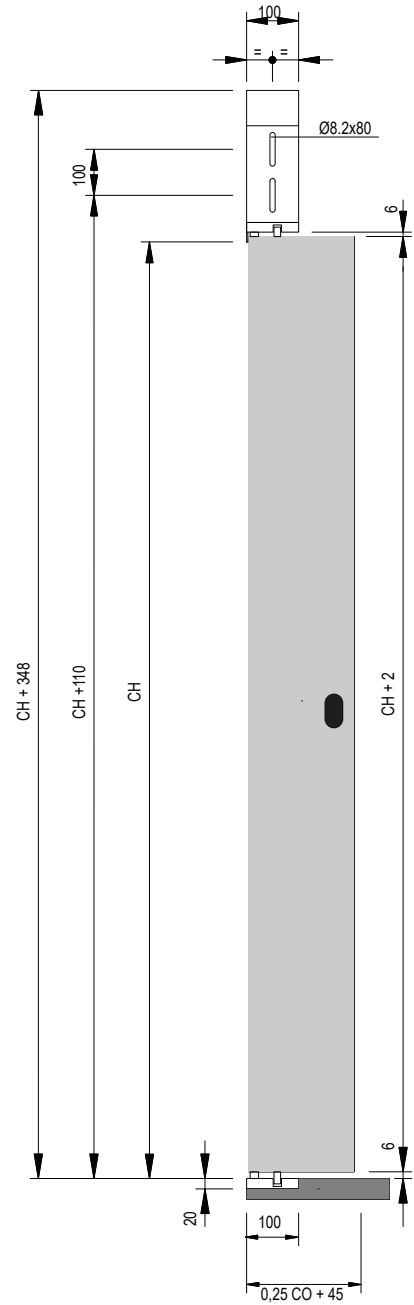
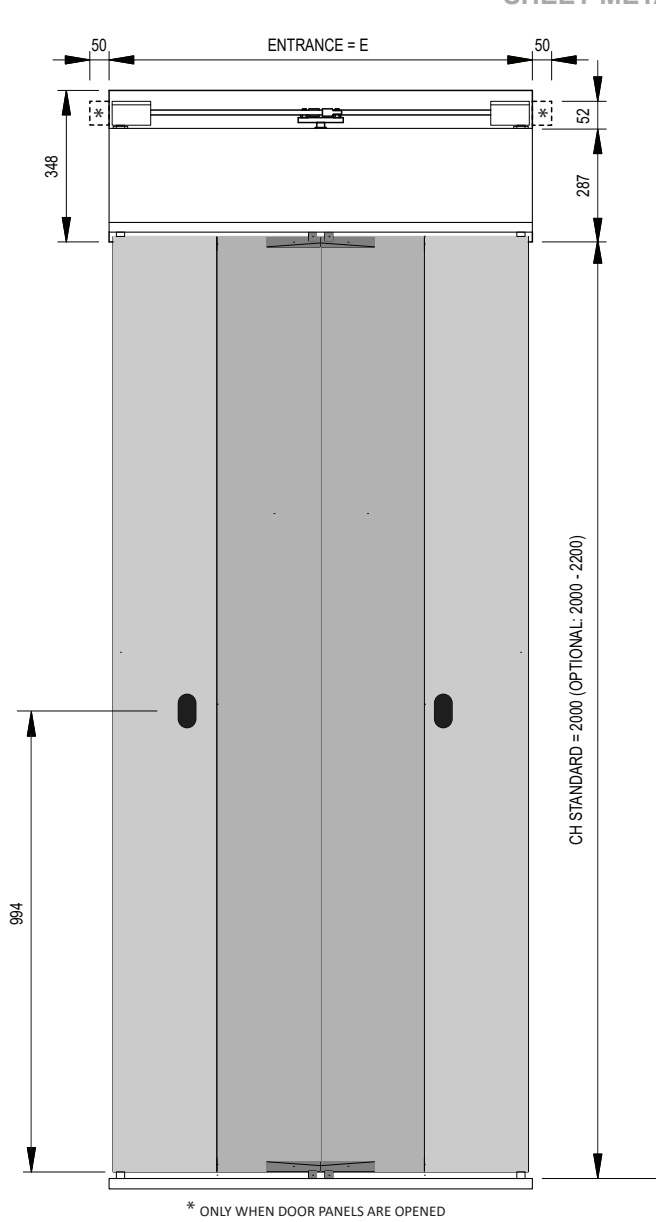

Notes:

- If not otherwise indicated all dimensions in mm.

Technical drawing

SMALL VISION

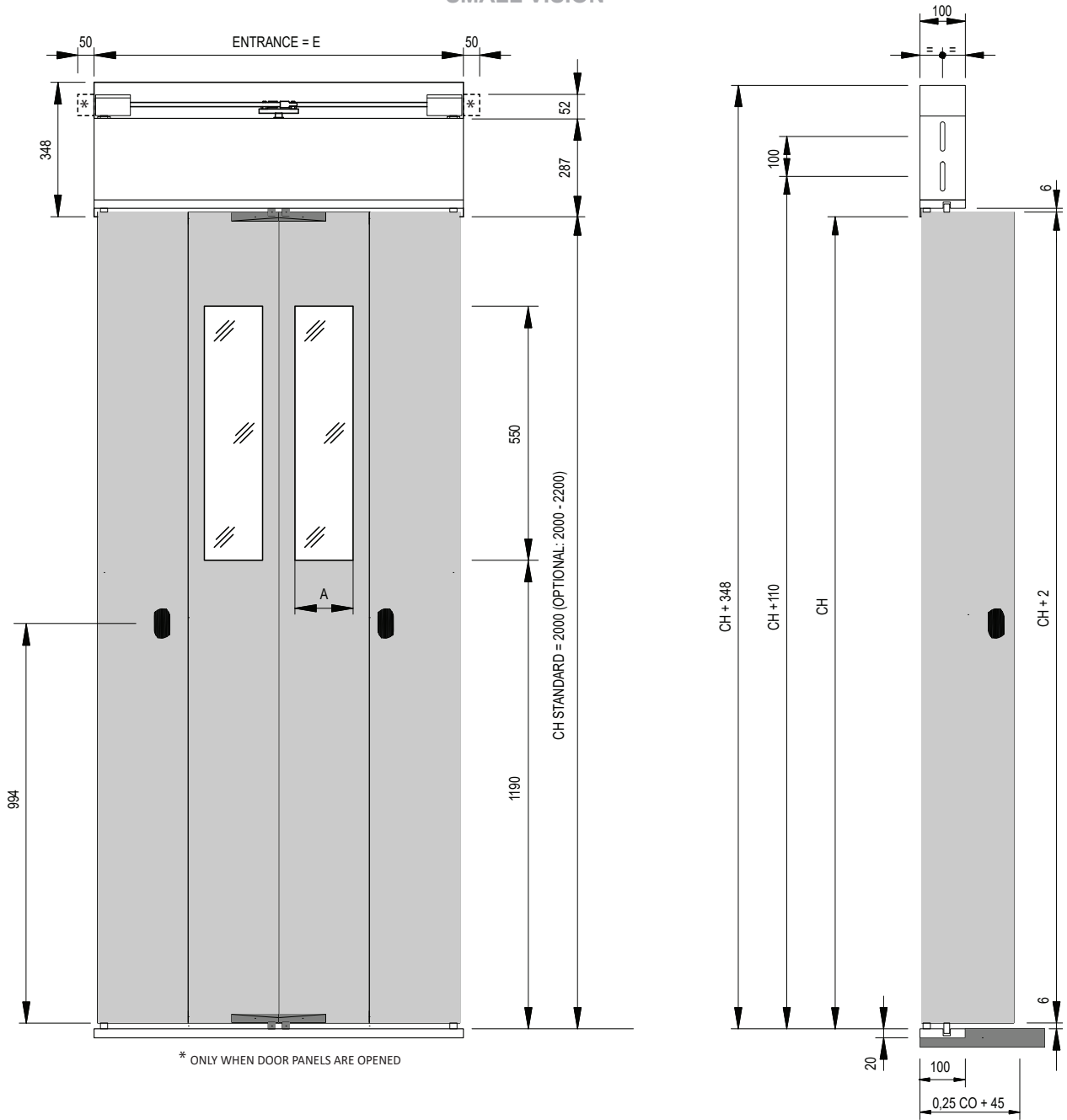

E	650	700	750	800	850	900	950	1000
A	37,5	50	62,5	75	87,5	100	112,5	125

Technical drawing

BIG VISION

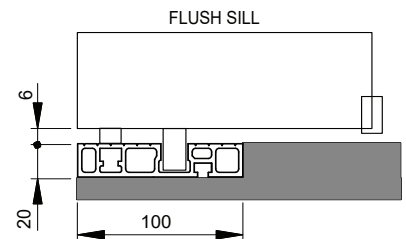
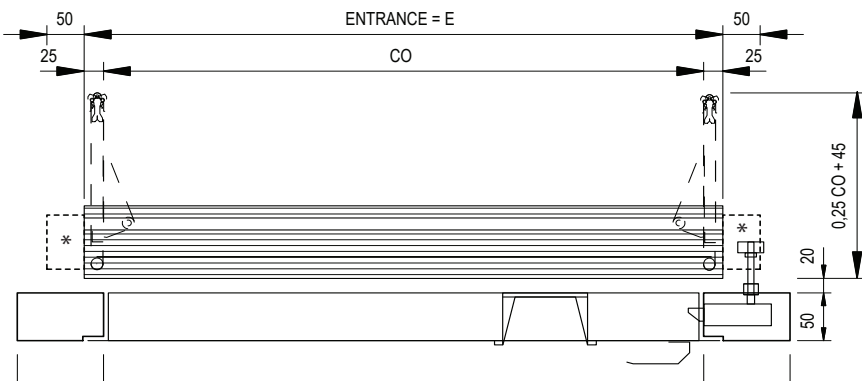
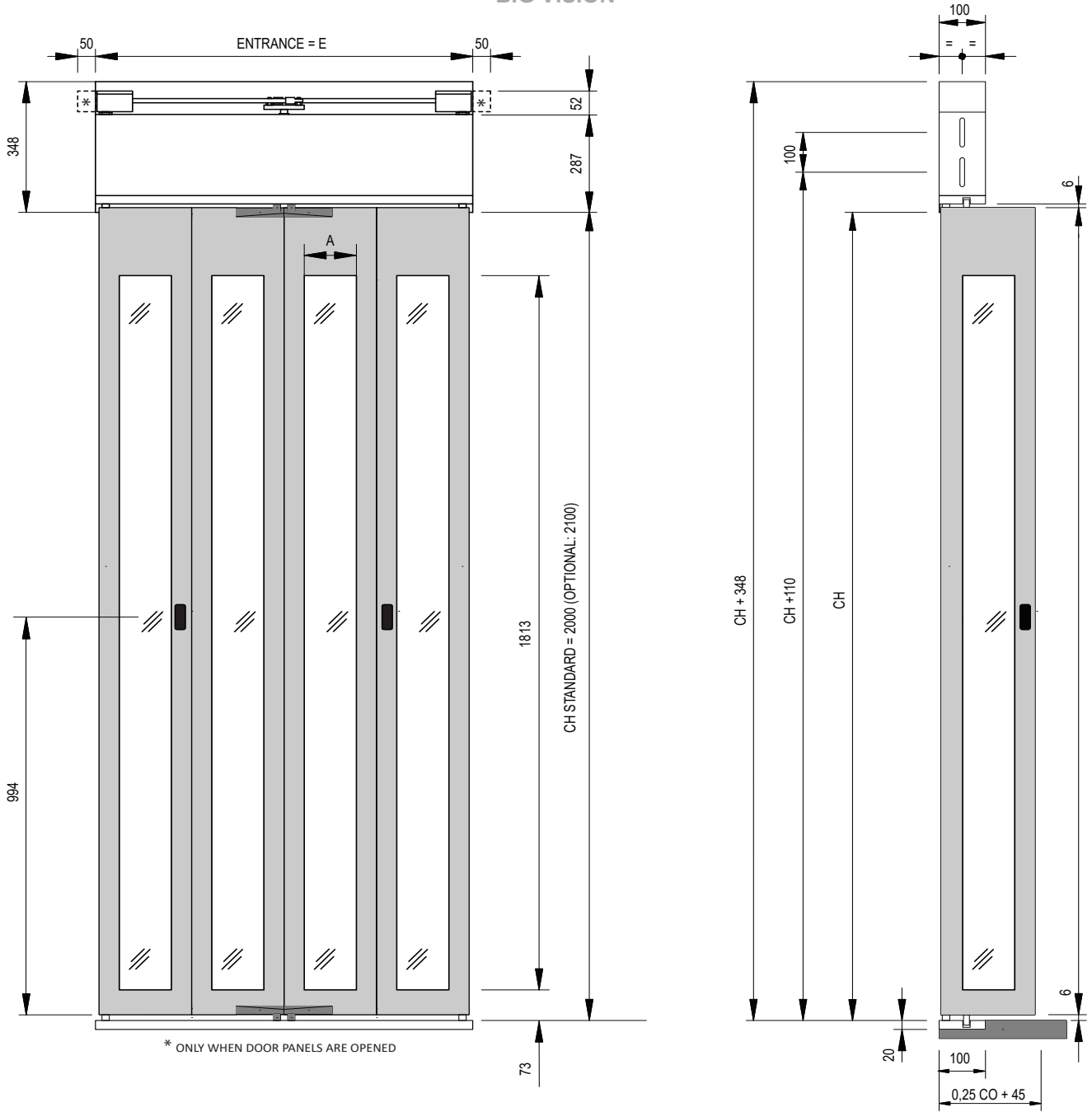

E	800	850	900	950	1000
A	67,5	80	92,5	105	117,5

Electronic module support

TYPES OF SUPPORT*

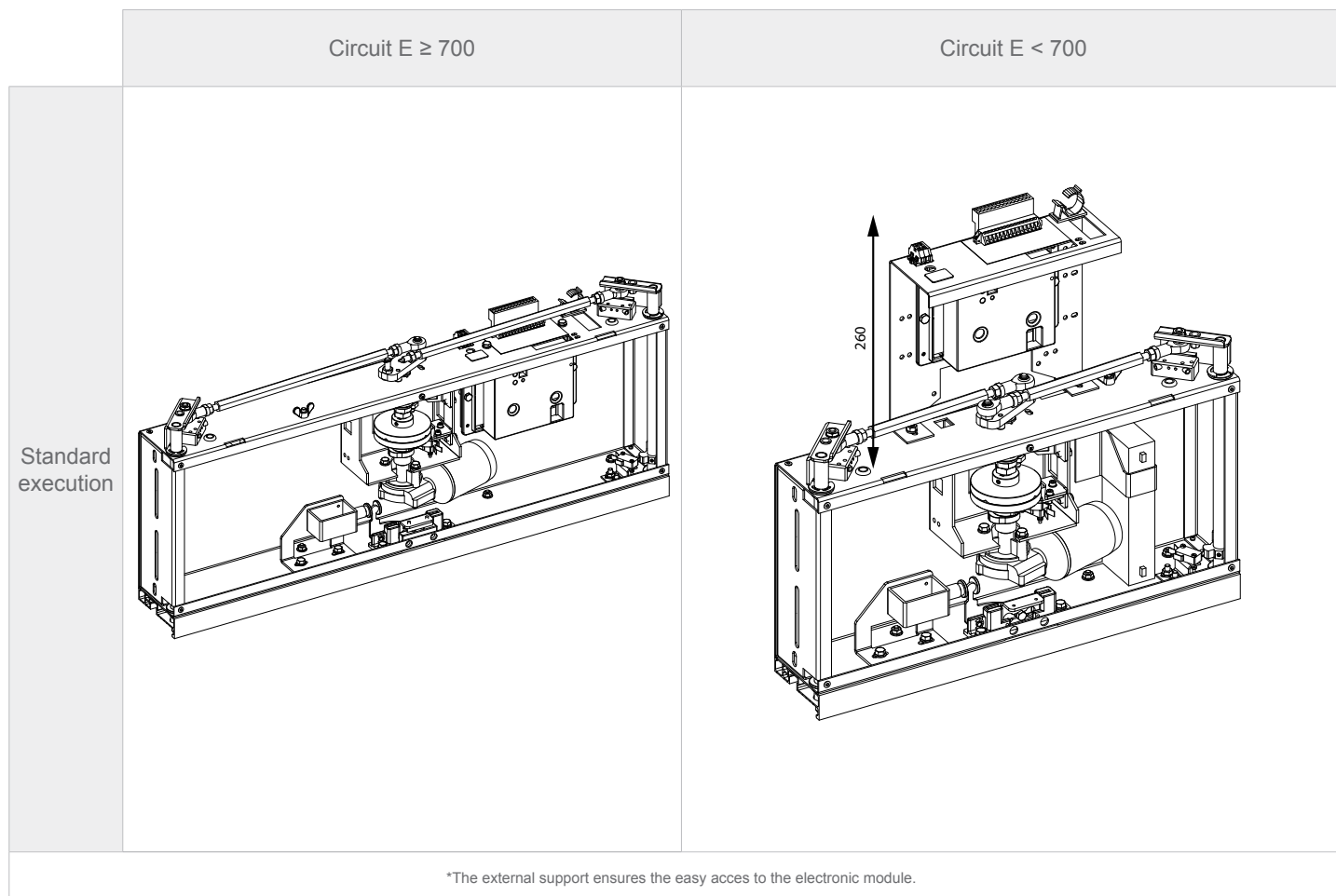

ΠΡΟΣΟΧΗ

ΓΙΑ ΝΑ ΕΙΝΑΙ Η ΠΟΡΤΑ G5-EM ΣΥΜΦΩΝΗ ΜΕ ΤΙΣ ΑΠΑΙΤΗΣΕΙΣ ΤΟΥ ΚΑΝΟΝΙΣΜΟΥ EN81.20, ΠΡΕΠΕΙ ΝΑ ΔΙΑΣΦΑΛΙΖΕΤΑΙ Η ΑΔΙΑΛΕΙΠΤΗ ΠΑΡΟΧΗ ΡΕΥΜΑΤΟΣ ΣΤΗΝ ΠΟΡΤΑ, ΕΙΤΕ ΜΕΣΩ ΜΠΑΤΑΡΙΑΣ Η ΟΠΟΙΑ ΝΑ ΒΡΙΣΚΕΤΑΙ ΣΕ ΚΑΛΗ ΚΑΤΑΣΤΑΣΗ ΛΕΙΤΟΥΡΓΙΑΣ, ΕΙΤΕ ΜΕΣΩ ΕΞΩΤΕΡΙΚΟΥ UPS.

ΠΡΟΣΟΧΗ! ΟΤΑΝ Η ΜΠΑΤΑΡΙΑ ΕΙΝΑΙ ΣΥΝΔΕΜΕΝΗ ΚΑΙ ΤΑΥΤΟΧΡΟΝΑ ΑΚΟΥΓΕΤΑΙ Ο ΧΑΡΑΚΤΗΡΙΣΤΙΚΟΣ ΠΡΟΕΙΔΟΠΟΙΗΤΙΚΟΣ ΗΧΟΣ (3 "BEEP") ΑΠΟ ΤΗΝ ΠΛΑΚΕΤΑ, Η ΜΠΑΤΑΡΙΑ ΧΡΕΙΑΖΕΤΑΙ ΑΜΕΣΑ ΑΝΤΙΚΑΤΑΣΤΑΣΗ.

CAUTION

IN ORDER FOR THE G5-EM BUS FOLDING FOOR TO BE COMPLIANT WITH EN81.20/50, THE CONTINUOUS ELECTRIC CURRENT TO THE BUS DOOR MUST BE ENSURED, EITHER BY THE BATTERY OF THE CAR OPERATOR IN GOOD WORKING CONDITION OR BY AN EXTERNAL UPS UNIT.

CAUTION! WHEN THE BATTERY IS CONNECTED AND THE SAME TIME THE CHARACTERISTIC WARNING ALARM (3 "BEEP") SOUNDS, THE BATTERY SHOULD BE REPLACED, IMMEDIATELY.

Unlocking device kit

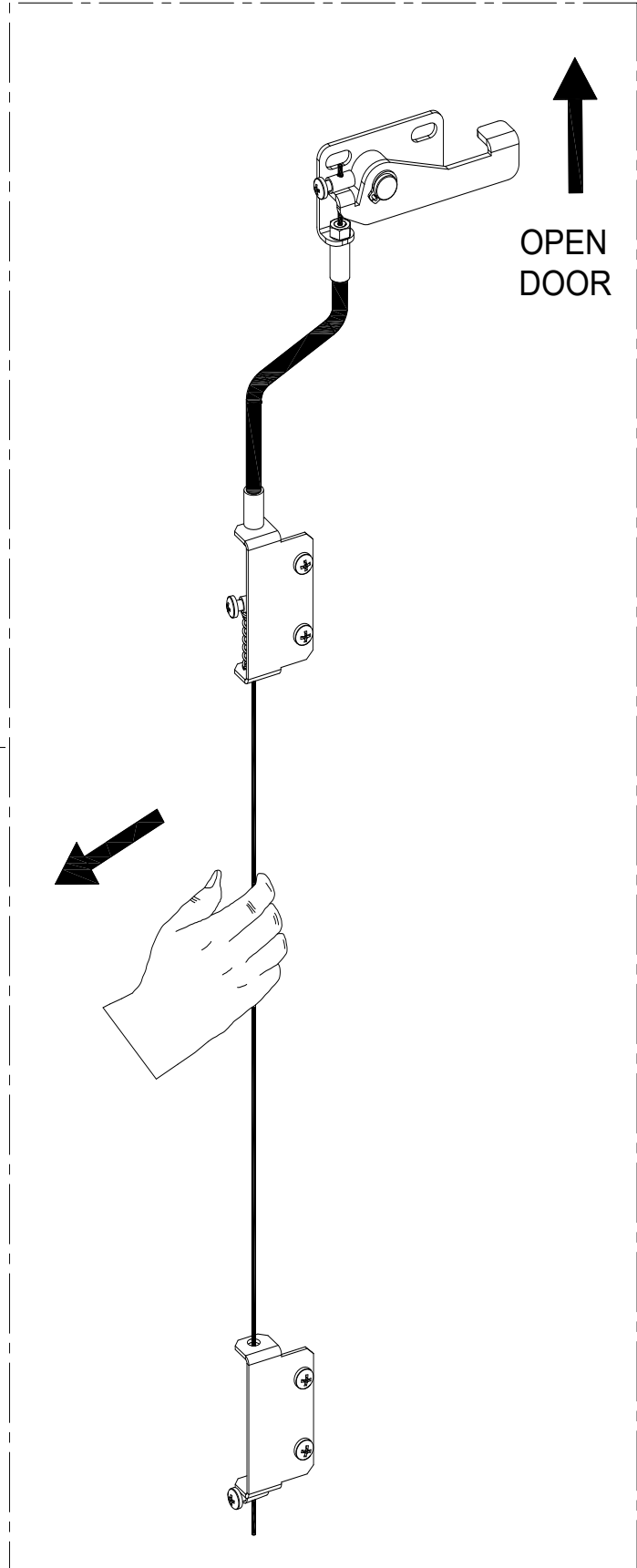
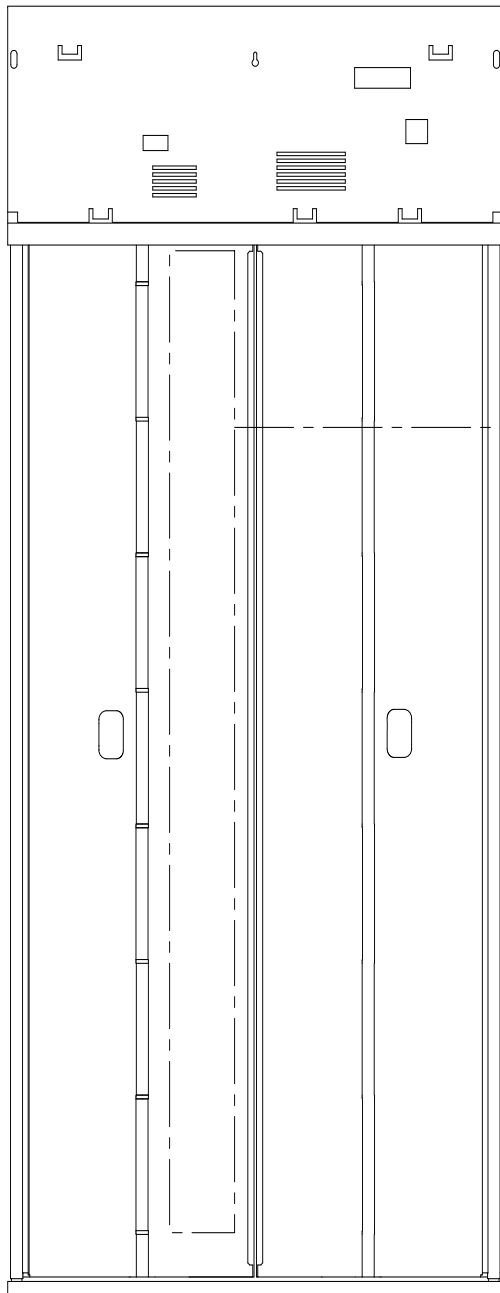



KLEFER S.A.

KILKIS Business Park 61100
KILKIS (GREECE)
Tel.: +30 23410 75730 - 2
General Commercial Register (GEMI): 014504535000
National Producers Register Nr.: 2581

Sales contacts

General: commercial@klefer.com

www.klefer.com